

Yale University

EliScholar – A Digital Platform for Scholarly Publishing at Yale

Cowles Foundation Discussion Papers

Cowles Foundation

11-1-2016

Three Essays on the Theory of Money and Financial Institutions Essay 2: The Exchange Economy, Money, and Markets

Martin Shubik

Follow this and additional works at: <https://elischolar.library.yale.edu/cowles-discussion-paper-series>



Part of the [Economics Commons](#)

Recommended Citation

Shubik, Martin, "Three Essays on the Theory of Money and Financial Institutions Essay 2: The Exchange Economy, Money, and Markets" (2016). *Cowles Foundation Discussion Papers*. 2516.

<https://elischolar.library.yale.edu/cowles-discussion-paper-series/2516>

This Discussion Paper is brought to you for free and open access by the Cowles Foundation at EliScholar – A Digital Platform for Scholarly Publishing at Yale. It has been accepted for inclusion in Cowles Foundation Discussion Papers by an authorized administrator of EliScholar – A Digital Platform for Scholarly Publishing at Yale. For more information, please contact elischolar@yale.edu.

THREE ESSAYS ON THE THEORY OF MONEY
AND FINANCIAL INSTITUTIONS ESSAY 2:
THE EXCHANGE ECONOMY, MONEY AND MARKETS

By

Martin Shubik

November 2016

COWLES FOUNDATION DISCUSSION PAPER NO. 2055



COWLES FOUNDATION FOR RESEARCH IN ECONOMICS
YALE UNIVERSITY
Box 208281
New Haven, Connecticut 06520-8281

<http://cowles.yale.edu/>

Three Essays on the Theory of Money and Financial Institutions

Essay 2: The Exchange Economy, Money and Markets

Martin Shubik

November 25, 2016

Contents

1	A Process Approach to Prices	2
1.1	A Contextual Link	2
1.2	The equilibrium model of the efficient price system	2
2	Transactions and the Birth of Money	4
2.1	The Transaction	4
2.2	From General Equilibrium to a Game of Strategy	5
2.3	The Three Periods for a fully dynamic Model	7
2.4	Commodity or Paper Money?	7
2.4.1	Fiat, individual money and credit?	9
2.4.2	Money as an asset	9
2.4.3	Getting money into and out of an economy	9
2.5	National debt is a capacitance	10
2.6	Debt and Bankruptcy	11
2.6.1	Everyone issues an individual money-credit?	12
2.7	Central Banks, Commercial Banks the Interest Rates and Inflation	12
2.8	An Aside on Automata, Simulations and Playable Games	13
3	Embedding Economies into the Infinite Horizon with Overlapping Generations	14
3.1	Overlapping Generations	15
3.2	Durable and Perishable Assets	17
3.3	The Role of Risk	17
3.3.1	On Gambling and probability	17
3.3.2	Theory and practise	18
3.4	Space	18
4	From Statics to Equilibrium Dynamics and Then Beyond	19

4.1	Uncertainty, Innovation and Evolution	19
5	Appendix: The Logic of Institutions and Function	20
6	References	22

Abstract

This essay is the second of three. The first is nontechnical and in part autobiographical describing the evolution of my approach to developing a micro economic theory of money and financial institutions. This essay is devoted to a mathematical sketch of a closed economic exchange system with general equilibrium GE and rational expectations RE viewed game theoretically. It squeezes the last drop out of statics and an illusory dynamics in the form of the RE extension of GE with no other externalities beyond money and markets. The third essay builds on process models adding uncertainty, innovation, an active government, nonsymmetric information and other externalities that all lead away from a static equilibrium model to an evolving entity where competition involving finance and innovation is part of a dynamic non-equilibrium process.

1 A Process Approach to Prices

In this and a subsequent essay a step by step approach is adopted to laying on successive unavoidable complications to the basically accepted pure abstraction of the static, non-process, optimal price system in order to handle process in general and innovation in particular.

1.1 A Contextual Link

In the first part of the three essays I presented a more or less informal and partially autobiographical sketch of my search for a satisfactory theory of money and financial institutions. I argue that the very nature of an adequate theory of money involves an intimate intermix of abstract description of function with vast manifestation of institutional forms that perform the functions.

As many models are being covered here, only brief descriptions of the formal structures and solutions are noted along with some comments on some still open problems.

1.2 The equilibrium model of the efficient price system

Our point of take off is the Arrow, Debreu, McKenzie (ADM) demonstrations of the existence of an efficient price system in an economy with private ownership of the means of production and allocation of product by means of prices that are shown to lead to an efficient allocation of resources. As all control and timing aspects of firms and the timing of their production processes were dispensed with

in a masterful abstraction the essence of their main result can be illustrated by a model concerned with exchange alone among individuals powerless to influence price. $E(N, M, u^i, a_{ij}, R_{nm}^+)$. There is a set N of n individual; a set M of m commodities where each individual i has preferences that can be described by a utility function u^i whose arguments are given by the holdings of quantities of the m commodities. The initial holdings of any individual i are described by an array a_{ij} where $j = 1, 2, \dots, m$.

The various proofs of the existence of a set of prices as a sufficient signal to coordinate all actors operating purely in the interest of self with no further considerations of other aspects of the society or polity were, and remain striking.

For those who do not see the limitations implicit in the modeling they provide a striking intellectual base in support of a competitive free enterprise system. Unfortunately they prove more. The same impressive mathematical apparatus that shows the existence of fixed points that some call competitive equilibria can equally well be interpreted as prices calculated by a centralized socialist economy, where in order to run the production and exchange that takes place an enlightened centralist government provides prices.

Hayek [17] rightly pointed out the equilibrium analysis left out the critical role of information that differentiates the functioning of a dynamic competitive economy from one that is centralized.

The ADM results based on the conjectures of Walras stand as a beacon in economic theory. Part of the art of modeling in the sciences in general involves the ability to map our understanding and insights of the world around us onto an appropriate abstraction that serves to permit the theorist to answer one or more questions for which the model was designed. Here the basic question was the necessary and sufficient conditions for the existence of prices to allow individuals using this information to achieve optimal trade as though each faced a one-person optimization. The general problems of dynamics, information requirements and possibility of disequilibrium were not considered. The analysis should be hailed not as the final solution to the understanding of enterprise or socialized markets, but as providing the needed preliminaries to starting to construct and analyze process models capable of illustrating a dynamics that carries a system from a state at time t to a new state at $t + \Delta t$ regardless of considerations of equilibrium or disequilibrium. This is easier said than done. It is evident that no matter how one approaches economic dynamics it must lie at a lesser level of abstraction than ADM. The carriers of process must be specified before one can attempt to try to specify equations of motion. The carriers of process may be viewed as the rules of the game, be they societal, political and technological. A contemplation of how to formalize these rules while leaving room for generality but being able to cope with specifics in a general framework leads to a construction of a **Mathematical Institutional Economics**. The task of making this concept operational requires an emphasis on model building techniques that call for the ability to construct a myriad of individual models that are interrelated and can be woven together into a single fabric. Each of the many economic functions such as saving,

investing, forecasting, insuring, innovating, defaulting and renegotiating have to be modeled, analyzed and related. Complexity can easily overwhelm analysis; in order to forestall this the approach has been to break the many aspects of economic dynamics into bite size enabling us to produce many minimal institutional models that are able to carry each basic economic function.

The concept of **minimal institution** or mechanism can be mathematized. An institution is minimal in the sense that if any rule that is part of the structure is removed, the remaining structure cannot perform its function. For example, the institution "market" requires that a price forming mechanism be supplied; if any part of these rules is removed the institution will no longer be able to form price.

2 Transactions and the Birth of Money

As Adam Smith has already noted that given the existence of private property, the very foundations of economics are based on the two critical features of the **division of labor** and **trade**. Beyond these all else is elaboration and commentary.

2.1 The Transaction

In the beginning is the transaction. The American institutional economists regarded the transaction as a key factor in the measurement of economic activity. It is hard to define precisely, and many shades of difference can be proposed related to the basic questions being asked. Here as our basic concern has been with the emergence of money and markets we [11] utilized a level of analysis even more primitive than that utilized by ADM. We considered mechanisms that provide traders the opportunity to exchange commodity i for commodity j , for certain ordered pairs ij given any connected graph G of opportunities, we showed that there is a unique mechanism M_G that satisfies some natural conditions on the ease of trade involving the amount of information needed and the number of intervening trades involved. We showed that for $m > 3$ there are precisely three minimal mechanisms corresponding to three basic graphs, the star, the cycle and the complete graph. Among these three, the star has a distinguished commodity that provides the basic transaction property of a money. Given three or more individuals and four or more commodities A, B, C, D, \dots where D is the center of the star, if individual i wishes to exchange commodity A for B she does so by exchanging A for D and D for B .

The star formation and the complete graph are illustrated in Figure 1

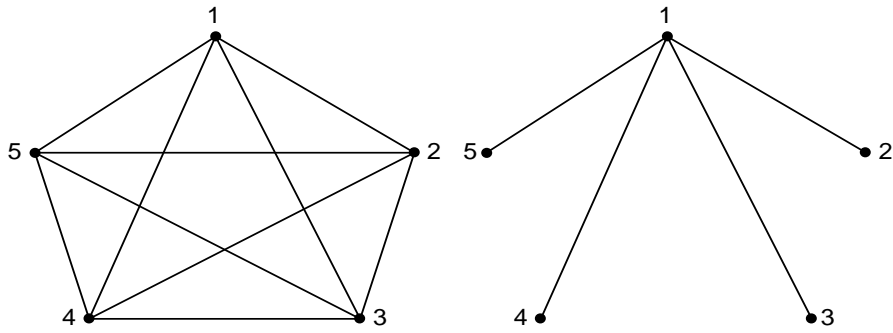

Figure 1
Graphs of markets

This analysis takes as a given that both the number of steps and amount of information required to implement a transaction fully are not without cost, but with little more than the basic insights of Cournot [8] and Jevons [20] it establishes that both individual markets and prices are emergent properties of an economy based on individual exchange.

The establishing of a money and markets as an emergent property is a cap-stone of static analysis. It does not deal explicitly with dynamics, it essentially shows that money and markets emerge as a mechanism independent of any preference assumptions. It is concerned only with the desirability of a trade mechanism that minimizes the resource consumption of trade and the complexity of information.

2.2 From General Equilibrium to a Game of Strategy

The production of a viable dynamic model of exchange at the same level of generality as ADM is not possible, as any dynamic model must be at a higher level of specificity. In particular a price formation mechanism must be specified. Fortunately there are two natural ways to construct a minimally complex price formation mechanism. They both have honorable roots in the 19th Century, being the Quantity Price Formation mechanism utilized by Cournot [12] and then the Price-Quantity mechanism (incompletely) sketched by Bertrand [5]) a French applied mathematician who wrote a scathing review of Cournot's book many years after its publication. The great mathematical economist Edgeworth [14] enlarged and partially corrected Bertrand's model. The fundamental difference between the two mechanisms was that Cournot's model used quantity as the key strategic variable, while the Bertrand-Edgeworth treatment stressed price as the key strategic variable with quantity entering in as constraints. These precursors of formal game theory models were the basis for two fundamental strategic market games that can be called the bid-offer models [27], [26], [29],[30] [12] and the price-quantity models [13], [10]. Without going into technical detail that is adequately covered in the references above the bid-offer models are no more than the amount of money chasing an amount of a good

$$p_j = \frac{\sum_{i=1}^n b_j^i}{\sum_{i=1}^n q_j^i}$$

where b_j^i is the amount of money offered by i for good j and q_j^i is the amount of good j offered by i . This model although microeconomic in detail has natural continuous way of aggregating strategies and when large numbers are considered leads to a natural interpretation for macroeconomic study.

The price-quantity model can best be represented by an ascending and descending histogram of prices and quantities corresponding to the offers for sale of a good at any price level and the quantities of money bid at any price level. A strategy in such a game for a participant i has four numbers per commodity j . they are $(p_j^i, q_j^i, \bar{p}_j^i, \bar{q}_j^i)$ where the p_j^i are the the personal bid prices of an agent i for commodity j and \bar{p}_j^i are the personal offer prices. An individual is permitted to be on either or both sides of any market. The q_j^i and \bar{q}_j^i are the limits on quantities offered by the individual at her prices.

Market prices are formed by the intersection of the bids and offers histograms. The market price formation mechanism is not continuous in the sense that a small change in a personal price or quantities offered could result in a large swing in market price or no movement at all.

This game provides a natural low information simultaneous bid model that can be extended to a representation of the sequential dynamic, double auction market utilized by many stockmarkets. As soon as information is released sequentially after every individual trade the information conditions quickly become horrendously complex. Practical details such as the speed and capacity of the actual market clearing mechanisms together with their vulnerability in creating unequal information conditions, become critical. A host of queuing problems are created that have no general solution but are of considerable ad hoc concern to those either benefiting financially from or regulating the fairness and efficiency of these markets.

Much of the work in general equilibrium theory has stressed equilibrium. This holds true even for the rational expectation dynamics of Robert Lucas [22], [34] and his followers. In contrast our concern in the study of money and financial institutions has to be on the whole set of feasible outcomes regardless of any particular solution concept. However a new theory should be able to obtain the accepted results from any good previous theory and extend its scope with new results. For this reason we utilize the relationship between the general equilibrium price model and the noncooperative equilibrium counterpart, not because we believe that the noncooperative equilibrium is an adequate solution concept for all social and economic problems, but because the strategy oriented noncooperative equilibrium analysis can answer any question that is answered by competitive equilibrium analysis and more thereby establishing the claim that the game theory strategic approach is capable of not merely encompassing the results of general equilibrium but can go beyond them, and as indicated below, because of its emphasis on process it provides connections to the institutions of our society.

The apparently aesthetic immutable appeal of general equilibrium price theory provides an enormous simplification to the forever in motion world of institutions.

From a viewpoint of the mathematics involved the distinction between the roles of equalities and inequalities is critical. Looked at in terms of economics, accounting and finance the presence of inequalities between the supply and demand for goods and services provides the way through the looking glass that separates the moneyless, timeless world of general equilibrium from the parallel world of financial control where money, cash flow conditions and bankruptcy are able to balance the books that carry the dynamics of supply and demand in constant disequilibrium.

When an economy with a full financial system is studied only for its equilibrium properties a paradoxical event takes place, a degree of freedom is not required in the description of the equilibrium and in its disappearance the apparent need for money, credit and the whole financial system disappears.

In order to make this broad assertion precise several other basic features of every modern economy must be added and analyzed. They are what serves as money and how does it enter and leave an economy; is credit needed and does it differ from money; are default conditions required; and is a government or outside player or referee required?

The answers to all of the above are yes and each one requires an extension of the original model and separate analysis before integrating them into a whole.

2.3 The Three Periods for a fully dynamic Model

Before answering each of the questions noted above a comment on the minimal complexity required for the full study of dynamics is noted. In order to catch the full spirit of time past and time future three periods are needed. Time past covers history and memory on which inductive decisions in time present may be based. Time present is the now when and where the decision must be made, and time future is represented in our current subjective valuations of the evolution of the system.

If we limit ourselves to a single finite period there is no history for the decision-makers to use at the start and as there is a finite termination at time T either there are no durable items carried into $T + 1$ or they are valued implicitly at zero.

One of the key features of any money that is more than a pure accounting fiction used only in the balancing of the books at equilibrium, is that it is a durable. The natural mathematics to portray an economic dynamics requires a recursive structure, the future is being constantly revalued with durables providing much structure.

2.4 Commodity or Paper Money?

The first monies were commodities [20], [30], [?] such as salt, barley, silver, and gold. History has shown gold as a prime candidate in its selection as a money.

Commodity money It is straightforward to build a one period model of an exchange economy that can actually be utilized as an experimental game if we consider

a single period where there are many individuals and each starts with an endowment of, for example, three commodities apples, oranges and chocolate bars, the last being also denominated as money. (see [27], [12]. They bid and offer simultaneously in the two markets and obtain their final consumption bundles. The mathematics looks like that of general equilibrium exchange, but with extra cash flow constraints.

If the constraints are not binding this means that for the transactions technology given, there is enough money. If the constraints bind then efficient trade cannot be attained and some means to relieve the constraints must be introduced.

There are several institutionally different cures that are sufficient to supply the necessary liquidity to achieve efficiency. They are:

- produce more commodity money;
- invent credit;
- improve the transactions technology, such as speeding up velocity;
- supplement or replace the commodity money with a fiat money.

The first cure requires an investigation of the production technology as happened when the gold standard was considered.

Utilizing gold as money avoids giving issue power to a monopolistic government, but gives the power of issue to the gold industry that may or may not be competitive. Shubik and Smith [28] have explored this possibility in some detail.

The invention of credit took place well before the formal invention of coinage and as the code of Hammurabi indicates it requires some form of government to enforce the laws of bankruptcy to resolve problems when a debtor cannot repay a creditor. This is a logical necessity if credit is to be granted.[29], [32]

The improvement of transactions technology has been in constant flux since the start of trade. With the advent of computers and almost instant communication the flow of information and some mass market financial transactions are now measured in microseconds. Transaction times depend on a mix of technological, institutional and socio-psychological factors and for every market there is some finite bound on the speed of transactions.

The last cure noted has been the replacement of a commodity money by a government fiat money.[30]This entails not only a major economic change in transactions technology but confers a considerable amount of extra political power on the government in its relationship with the private economy. A critical political debate involves the trade off between the concentration of governmental economic control versus the efficiency gain in the ability to change the money supply quickly.

Historically all of the four cures for adjusting the amount and distribution of the money supply have been utilized. Each merits and has received considerable specific investigation; but from the viewpoint of political economy and power the control of credit and fiat is the most central.

2.4.1 Fiat, individual money and credit?

A commodity money or individual private issue of a personal means of payment [33] or a bank or moneylender's granting of credit [31], [28] are all institutionally sufficient different ways to solve the necessary function of providing sufficient money or money substitutes.

In essence money and all forms of money substitutes are "trust pills" where the level of trust involved may depend on a myriad of ad hoc institutional details. The evaluation of credit is one of the central functions of the financial system.

2.4.2 Money as an asset

Both commodity money and fiat are commodities. The former is a real commodity such as gold (a durable) or barley (a storable consumable) with often lengthy and expensive processes need to increase the supply. The latter is legally defined by a government and generally can be produced monopolistically by a government with essentially low resource costs and with great speed, such as by running printing presses or by electronic methods.

Ownership of a commodity money involves explicitly only one individual and the commodity, "Jones owns a two-ounce bar of gold". Government is present only implicitly in the sense that it has declared gold to be the official currency and has specified standards of fineness and weight, names a unit of measure and enforces the law on its use.

On a balance sheet the gold appears as an asset on the left side. It can be balanced on the right side under the special residual category of ownership.

The description of ownership of a fiat money is somewhat trickier. The statement that, "Jones owns a twenty dollar United States note" puts it on the left side of his balance sheet as well as under ownership; but should this bill also be listed on the government's balance sheet as a debt owed to him by the government? Operationally as all that he will receive if he were to present it to a government bank is another bill, the fiction of fiat as a two party paper where the money really is a debt instrument with Mr. Jones and the United States government as counterparties is in operational fact a fiction. The basic nonsymmetry means that like gold its value is determined by how people value its future worth. Institutionally people evaluate the future worth of gold taking into account its future worth as a means of production, consumption (jewelry) and payment. Fiat money must be valued essentially only at its future worth as a means of payment. Given these factors as Ricardo noted it is easier to trust gold than the politicians controlling a government issuing fiat.

2.4.3 Getting money into and out of an economy

We have discussed the ways for adjusting the amount of money upwards in the economy. The mechanism to adjust the money supply downwards are not necessarily the

same. Three means for removing money from the economy are:

- Taxation,
- International trade, and
- Financing the national debt.

Taxation is neither a flexible instrument nor politically tenable instrument for the flexible variation of a money supply. Its primary economic functions lie elsewhere. These statements are also true for international trade.

The instruments most naturally relevant to both the short term and long term money supply are the national debt and the central bank's instruments available to influence the money interest rate. These require a separate and more detailed institutional and mechanism discussion than can be given here. The two basic features of how debt differs from money and why the national debt is a flexible instrument to control the money supply can be specified without dealing with the details on the power of a central bank on the interest rates for money and debt.

Debt is a two-party instrument The predominant form of debt involves two party paper where one party is a real or legal person such as a corporation and the other is a bank or some other lending institution or a like private individual.

The basic aspect of debt as contrasted with money is that it is an instrument that involves at least two parties and two time periods. Viewed abstractly it is an operator through time. At its simplest it links the increase of available money at time t with a decrease in available money at time $t + 1$. At time t individual i exchanges money she owns for an IOU issued by individual j . At period $t + 1$ the individual j pays the agreed upon amount of money to i for the return of her IOU note which is then extinguished. This is simple and straightforward; but one of the joys of finance is that there are many shadings of a simple transaction that are complex and opaque in the extreme to all but the experts and their lawyers. An IOU note may become three-party paper if it is specified that it can be sold to a third party; payments may involve front end loans or there are other means to disguise the difference between the interest rate stated and the rate being paid.

As any individual who has borrowed from a bank knows there is usually a considerable disparity in the size and legal power of the parties. Those with the deep pocket and an appropriate corporate structure can sue or withstand suing with impunity; a private individual without deep pockets cannot resort to these tactics.

2.5 National debt is a capacitance

The difference between the national debt and individual debt is in the purpose, timing and powers of the parties involved.

The government is, in general, even bigger than the biggest bank. A reasonable rule of thumb is that there are three economic sizes that have qualitative differences in strategic power; they are the small private individual and business; the large bureaucratic corporation and the still larger and more broadly powerful national government.

Alexander Hamilton already understood that in the overall guidance of an economy the presence of a reasonably sized national debt was more of a blessing than a burden. He also understood that the homely analogy between personal and private debt that is used by demagogues and believed by much of the public even today was fundamentally misguided. Without going into detail the government of a complex society requires a whole structure of term financing or different time lengths in the financing of different projects varying from instantly ameliorating the damage from a natural disaster to the long term financing of a defense system, a space program or a transportation network. By issuing notes and bonds a government creates a debt that may be paid for by individuals, banks and other institutions that buy government debt paying at least in part, in fiat money thereby removing it from the economy. If it wishes to inject more money quickly into the economy it can do so by buying back some of the debt paying for it with crisp newly printed currency or in ciphers crediting the owners. The electric circuit analogy is direct. A large debt, in its simplistic form, is like a capacitor in an electrical circuit. The capacitor stands by to supply extra electricity in times of high demand and it also stands by to collect extra energy when it is not needed.

There is an optimal size for the national debt that grows with both the overall size of the economy and the size of the expected fluctuations.

The simplistic explanation serves to illustrate the principle and basic purpose of a national debt, but advice on its use depends on further details concerning political goals and the specific power structure in the decisionmaking in a complex political and bureaucratic society. This requires considerable elaboration on public finance.

2.6 Debt and Bankruptcy

Government debt has been noted above, where small individuals trade with the clearly most more powerful counterparty in the economy. This has both advantages and disadvantages. Because government is the only legal producer of fiat, if faced with an immediate need to redeem debt from its citizens it can, at the risk of inflation create the funds to repay its debt rather than go bankrupt. If sovereign debt is held by other countries a different array of problems is faced; however for the individual citizen, as a good first approximation central government debt is default risk free. This does not hold for any other form of debt.

The logic of looking at the whole array of feasible states that can be attained by a process model of an economy forces us to specify default, bankruptcy and reorganization laws.

Another fundamental complication in a modern economy has been that the corporate form has enabled the separation of management from ownership and introduced limited liability. As control is determined by voting it becomes feasible for controlling interests to bankrupt a firm in a way that is profitable to them by letting it take risks that they would never take were they not protected by the bankruptcy and default conditions.

2.6.1 Everyone issues an individual money-credit?

We noted above the logical possibility that all issuers could issue their own money, or credit. This observation depends delicately on a play of words, involving the concepts of international trade clearinghouses, bridging finance and accounting money. Fisher Black raised this [6] possibility. Strange as it may seem, utilizing the work on strategic market games Sorin [33], using results of Sahi and Yao [24] was able to produce a model that could be used to serve as an experimental game that showed [2] the nature of the apparatus for which this possibility is true as well as the empirical considerations against its practicality.

The analogy between international trade and individual behavior comes when we consider many currencies. Each country issues its own money that in fact is used by its inhabitants as already described. These observations can be extended to international trade by the introduction of a completely efficient clearinghouse that not only takes in all bids and offers for sale in different currencies, but immediately solves the fairly straightforward set of linear equations needed to calculate relative prices that clear all markets. Furthermore the mechanism also requires failure to deliver penalties as the financial clearances may not coincide with the final delivery of the physical goods [19]. If these conditions are imposed then students can sit in front of computer consoles sending in bids denominated in their private currencies and offers denominated in goods to a central computing system. If they are not allowed to renege on the delivery promises then the experiment verified the predictions of the theory. As instant prices guarantee that the books are always in equilibrium no matter what is issued the individual monies are always offset by perfectly offsetting demands against them hence are better described as "accounting money" as fiat monies remain after trade.

If failure to deliver penalties are not imposed the experiment showed violation of the equilibrium.

2.7 Central Banks, Commercial Banks the Interest Rates and Inflation

The concepts of commodity money, fiat money, accounting money, commercial bank money and credit of various sorts meld into each other with much institutional detail and history being involved as well as formal basic properties. In particular a

natural question to ask is, "If a country has a central bank does it need commercial banks?" We note [28] that commercial banks are not logically necessary at a high level of abstraction a central bank could perform any function usually assigned to a commercial bank. But as was illustrated by the error prone arthritis in the decision-making apparatus of the Soviet Union's banking system with branches rather than independent profit centers, the bureaucratic, information and control problems were a considerable drag on function. Most countries recognize the relative gain in efficiency in having many of the needed functions for servicing and evaluating many consumer and producer loans needed in every day life, handled by profit seeking independent banks rather than by parts of the central bank bureaucracy. The choice depends on the details of costs and the efficiency of financial mechanisms.

The private banks play such a key role in accepting deposits of savers and in lending a mixture of their IOU notes and fiat money that common parlance calls private bank IOU notes money and treats it as if it were identical with government fiat money. For many purposes it performs the same functions for most of the public most of the time. In periods of crisis this is no longer true.

A private commercial bank was primarily concerned with commercial purposes and consumer financial needs. A central bank has many of the burdens of the state involving the overall guidance of the money supply, interest rates, and the execution of actions called for by government concern with inflation and employment.

The theorist looking at prime functions and minimal forms may be able to produce lean and insightful models involving central banking and its interface with commercial banking, investment banking and the myriads of subfunctions that the banking system performs, but the distance between high theory and practise is so large that the study of both central and commercial consumer and investment banking are important subdisciplines in their own right

2.8 An Aside on Automata, Simulations and Playable Games

I have noted above an experiment run with individuals issuing their own IOU notes. This illustrates that even abstract theory may permit experimentation however the results can provide a paradoxical interpretation. The evidence may support the prediction of behavior in the game, but the detailed conditions required to make the game playable may indicate its limits in application. Similarly in modern finance stress testing has both its function and limitations. In running a simulation of an economy not only are the mechanisms and institutions modeled but the equations of motion of the individuals are also provided. Thus the individuals are automata with neither memory nor passions other than those supplied by the modeler.

Stress testing is more or less routine in finance and the use of experimental gaming is growing in economics, but it is possibly worth considering that the largest value to both the practitioner and theorist in using these techniques may be the challenges to both in making explicit the assumptions required to get either a game or a simulation

to produce its output.

3 Embedding Economies into the Infinite Horizon with Overlapping Generations

We have suggested above that consideration of rules of trade, credit and varying the money supply all call for the role of government. Technically an analytically tractable model of the economy has government as an atomic player and natural persons and small firms as individually strategically powerless¹. Even with keeping to this somewhat impoverished model there is much to consider before satisfactory dynamic models² covering endless time $(-\infty, \infty)$ can be considered. The dynamic programming rational expectations fix can take care of a low dimensional structure with an aggregate commodity representing the output of the economy and a money that can buy it. This representation models time as a discrete set of periods of equal finite length. This approach has been developed considerably by Lucas [22] and associates consider a low dimension recursive structure with an arbitrary time grid, while von Neumann [35] considered a purely technological multi-dimensional economy with fixed returns to scale and only an implicit concern with preferences only to the extent that more is implicitly considered to be better than less. Karatzas, Shubik and Sudderth [21] recast the Bellman [4] equations in terms of a dynamic strategic market game. But the stress on rational expectations and the equilibrium aspects of a noncooperative solution give little, if any insight into the problems in understanding a dynamic economy out of equilibrium that utilizes some form of learning to proceed from t to $t + 1$. Whether this heads towards an equilibrium path is not known in general. However the comforting feature of having all individual expectations match provides enough extra conditions for one to show an equilibrium path consistent with the appropriately selected initial endowments. Unfortunately as the economy appears to be in constant disequilibrium with the dynamics sensitive to contextual considerations the pure dynamic programming approach appears, at best, to be a generator of highly simplified analogies rather than as an applied tool without considerable ad hoc modeling.

Even without getting close to Political economy and a world with many vague uncertainties four large modeling problems remain,

1. The Debreu book [9] ignored the problems of many generations and offered a mathematically elegant way for avoiding having to deal with three other critical

¹Unfortunality the large corporations are so large that for many questions one needs to consider them to be big enough as to merit introducing them as oligopolistic agents; but in order to do so usefully this appears to require ad hoc modelling to be able to investigate and answer any specific question.

²Even if we set aside evolution, culture, social relationships, politics and society.

general aspects of the economy that must be considered in a process model. They are the existence of

2. durable and perishable assets;
3. simple abstract uncertainty;
4. space.

The last three were all taken care of incidentally by enlarging the commodity space considered, thus the possibility of dealing with a durable was avoided by redefining a commodity such as an automobile by a sequence of goods by relabeling the economic good as a different commodity in every time period it exists, thus an automobile is labeled "Automobile one-year old at time t " that becomes a new commodity "Automobile two-years old at time $t + 1$ ". The original m dimensional commodity space is increased to a space of dimension $m \times t$ where t is the number of periods to be considered. Similarly we considered a finite set of uncertain states and a new commodity is defined as "a bushel of wheat that exists at time t if it rains". We may also take care of space by cutting up the map into k zones and further specify the definition of a new and more complex commodity that includes the commodity located in time, and space and in uncertainty. Thus almost all of the commodities are not real but are future contingent promises to deliver in space and time contingent on events. Implicitly they are rather sophisticate financial instruments in contrast with "one banana now".

For the purpose of exploring the existence of a price system that in equilibrium clears all current and future contingent markets these enormous simplifications work and the crowning achievement was to show that an economy with complete markets and the appropriate ownership and preference conditions has an efficient price system.

As soon as one tries to construct a process model based on the general equilibrium model with complete markets that could serve as the basis of a playable game all of the simplifying abstractions must be deconstructed. In each category the process model requires extra detail. Space, time and uncertainty all call forth many extra conditions even at their highest level of abstraction in a process model. A critical role in the construction of the process models is to determine what are the minimal features that must be added to the non process model. The term "minimal institution" or mechanism is used to show that there is a natural next level of complexity that can be added and almost all of the basic new abstractions appear within the existence of three time periods, a Bernoulli random variable, three or four individuals, and four or five commodities

3.1 Overlapping Generations

The brilliant work of Maurice Allais [1] with a clearly macroeconomic flavor to it, was followed many years later by Samuelson's [23] perceptive microeconomic treatment of

overlapping generations utilizing money as a means of transferring purchasing power across generations of self centered individuals.

The Samuelson work was clearly in the spirit of competitive equilibrium analysis with the explicit analysis of money as a durable store of value. For simplicity he utilized unisexual individuals with two states, young and old with a loan market that permitted the young to save for their old age. reproduction was not given explicitly but can be added exogenously.

Figure 1 shows the essentials of an ongoing society with overlapping generations. There are two basic parts: The infinite tape on top represents the overall context in which the economy is embedded. This includes the society and polity together with all laws and customs of the society. There can be a whole array of instructions and resource flow between any period T and $T + 1$ on the infinite tape.

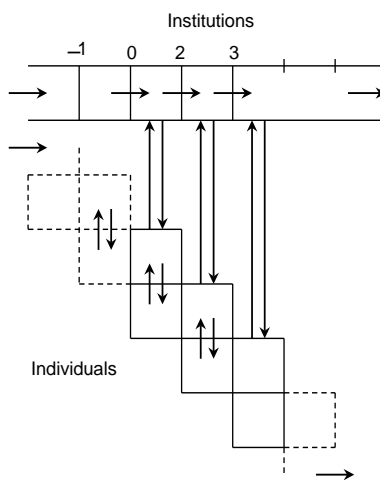

Figure 2
Socio-political context and overlapping generations

The instructions are not represented explicitly in the figure; but it is as though there is a reading device present at time T that reads the instructions on the tape, combines them with the instructions and resource flows coming in from the natural persons and then issues instructions that updates the system to $T + 1$. This includes both long and short term information such as "you will be expected to vote in two years time". The lines between each age group of the natural persons and the tape have arrows going in both directions indicating that at each period there are resource and information flows going in both directions between the legal persons and social institutions of the society. Left out of specific description are the resource and information flows among the living natural persons.

Even after over 70 years of work there are still many open problems in overlapping generations economics, finance, demography and evolutionary modeling. There are still considerable difficulties to be faced in obtaining tractable bisexual models. A

good summary of OLG and competitive equilibrium is in [15] and the work on OLG is still active [7]. In order to bring

process models closer to reality and to investigate the nature of competitive or controlled markets at least birth death processes, inheritance and other resource transferal devices must be made explicit.

3.2 Durable and Perishable Assets

The ADM models finessed the distinctions among perishable, and durable goods. When a process model is considered this cannot be done with ease even invoking rational expectations. If nothing else the distinction among the physical properties of the goods and the stock-flow problems in handling production indicate that it is difficult to seek great generalization, but is possible to construct reasonably good ad hoc models (see, for example [28] Chapter 5).

3.3 The Role of Risk

The finesse utilized by ADM worked excellently for the existence proof of an efficient price system and completely obliterated time and uncertainty. Even a minor attempt to face an operational connection with reality calls for the abandonment of complete markets and the myth of the holy Grail of the perfect portfolio for the 100% hedge.

3.3.1 On Gambling and probability

The games with tightly formal rules, be they Backgammon, Blackjack, Roulette, Chess, Poker, and Go have all served an important role in the development of a formal study of probability theory, game theory and computer science.

The reason is that all of them have formal rules with few if any imponderable features from outside of the game so that mathematicians have been able to build precise tools to investigate the intricate combinatorics and informational problems that provide a platform for investigating problems in insurance and the mechanism design of incentive systems.

Uncertainty enters the economy in many forms the two key manifestations are:

- Exogenous and
- Endogenous uncertainty.

In other words uncertainty created by Nature or outside forces, and uncertainty created by the strategic behavior in individual interaction. These differences can and were introduced at the highest level of abstraction by considering Nature as a formal random player in a game of strategy. This treatment is all that is required to enlarge the ADM economy, rid it of complete markets and turn it into a process model.

3.3.2 Theory and practise

The elegant abstract theories of probability and games permitted great strides towards dynamic models of the economy; but preceding and then together with theory the qualitative aspects of risk were observed and applied to economic life. In the development of the many applications of risk to all aspects of society since the late 17th century as betting and insurance became better understood, formalized and institutionalized, the many subdivisions and specialities in the study of risk appeared. For those interested in application and willing to actually deal in risk the institutional details are of basic importance, thus we have:

- Gambling risk involving formal games such as Bridge, Roulette, Poker, Blackjack, also board games including Backgammon and Monopoly;
- Sporting event risks such as baseball, tennis, horse racing, ice hockey, cricket, basket ball
- Risks pertaining to property such as fire, flood and other weather damage;
- Risks pertaining to individuals such as an array of accident and health problems;
- Economic, institutional, managerial and entrepreneurial risk such as product liability, strikes, computer system hacking, theft, defalcation;
- Financial market risks including identity theft, computer system malfunction, information leaks, extreme volatility, and the magnification of leverage dangers;
- Societal and political risks including attempts to assess the probability of riot, government collapse, rebellion, and war;
- So called “Acts of God” that may even nullify existing contracts; a major volcanic explosion or collision with a large meteor.

3.4 Space

The seminal work of Richard Hotelling [18] considered competition along a line, but there is little that can be said in general about the treatment of competition on a sphere ³ but there are many cases where an explicit question is being asked, such as where to locate a new factory, or global transportation cost minimization or grid lock avoidance. They can be cast and analyzed as specific operations research and economics problems but much is heavily the domain of straight operations research

³Although many an individual who is not a mathematical economist could easily spend time ridiculing the idea as a candidate for some form of esoterica prize, there are good logical reasons to consider competition on the torus as a way of taking competition on the plane into three dimensions.

and is classified often under regional science with practitioners such as Luc Anselin, Martin Beckmann, Walter Isard, Paul Krugman, Kai Nagel.

The work to date has had little to do with monetary theory, except for the production of arguments in favor of or opposed to common currency zones and in the design of bidding and queuing systems such as the various stockmarket mechanisms. The importance and complexity of the intermix between transportation physical systems and the information and control financial networks is recognized, but there are few general principles offered by theory and, at best practical problems in international trade must be resolved on an ad hoc basis taking into account both political considerations and non-price competition, such as innovation, left out of the Walrasian paradigm.

4 From Statics to Equilibrium Dynamics and Then Beyond

In the sketch of markets, money and credit given above the goal is to build process models out of the very cryptic ADM equilibrium model and to ask what are the minimal representations that enable us to do so.

The key to the whole approach is to understand that there is a brief middle ground between the static abstract broad sweep of general equilibrium and the overwhelming variety of institutional worlds of dynamic mutating economies in a constantly evolving disequilibrium. The many institutional structures call for ad hoc studies to answer any specific questions; but before the Pandora's box of the multitude of institutions overwhelms the broad theorist we can lay out the minimal institutions. With no more than three periods, the past, memory or history, the present or now and the future or expectations created now provides a sufficient basis required by the logic of economic optimization to derive a relatively manageable set of minimal economic institutions needed to perform economic functions such production, exchange, saving, investment insurance, taxation and subsidies. With reasonable restrictions, with only initial conditions covering history and with the existence of many durables restricting the scope of the future, without even having to invoke the added constraints imposed by the society and polity the necessary economic functions of a dynamic economy require sufficient mechanisms to provide the functions. The recent book of Shubik and Smith [28] and the many articles by many others have been devoted to the many details required for the building of process models.

4.1 Uncertainty, Innovation and Evolution

Essay 2 is devoted to sketching the tasks in turning the general equilibrium system into a class of process models, doing so required the invention of markets an money, credit, bankruptcy laws and other minimal institutions as sufficient devices to perform

the necessary economic and financial functions of dynamic economic systems. Figure 3 indicates what an institutional guidance system for a dynamic version of the general equilibrium models requires for a complete portrayal.

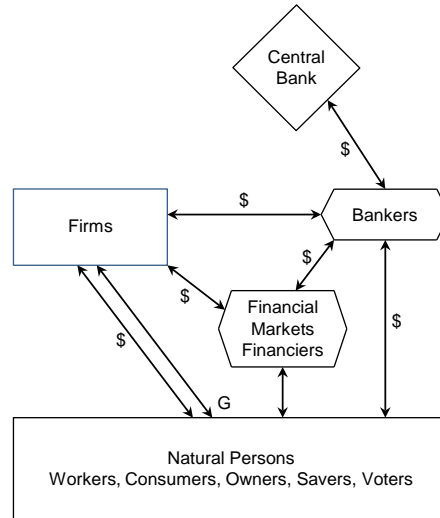

Figure 3
A financially guided economy

All of the above has been needed to extend the insights available from the study of efficient prices and the allocation of goods and services in a price organized society to process models. The conversion to process models is more of a beginning rather than just an interpretation of the old. In particular the world we live in is bathed in a welter of uncertainty where large oligopolistic agents strive to innovate in an environment where money and financial instruments are used in evaluation and guidance to assign the funds needed to act. The blend of risk, information and innovation produce an evolutionary system far more related to the predictions of Schumpeter, over a hundred years ago [25] than to general equilibrium.

Essay 3 is devoted to indicating how the two very different views of price and innovation competition fit together and point to a different vista of competition in the economy ahead.

5 Appendix: The Logic of Institutions and Function

In the beginning there was no formal economy. The basic **first step towards complexity** was the **division of labor** and **ownership** that was applied to both **production** and **exchange**. Essentially everything else involving the emergence of great complexity is commentary.

- The timeless mathematical abstraction of general equilibrium reflected the basic properties of labor, ownership, production and exchange; but a world with time, space and uncertainty was only implicit in the broad description.
- The turning of this nonprocess description into process models requires making explicit the various functions and the mechanisms, forms or institutions that are the carriers of process.
- limiting ourselves to a one period model if there are any costs whatsoever to exchange the necessity of a money and markets is established
- From the basic requirements for price formation it is shown that there are only two basic price formation mechanisms. The quantity models can be associated with Cournot and are congenial with conventional supply and demand analysis; and the personal price or bidding and offering models that can be associated with Edgeworth and Bertrand that fit auction and stockmarket mechanisms and the micro details of information and evaluation in financial markets.
- Payment in money implies the importance of cash flow conditions and efficiency conditions force the consideration of the meaning of enough money and liquidity. The first requires the invention of credit, money substitutes and methods to control the money supply. The second calls for the specification of the technology of the trading mechanisms and consideration of the grid size or the minimal amounts of time to complete transactions.
- The existence of credit or money substitutes requires that bankruptcy rules be specified to cover situations where the system can attain a state where a debtor is unable to pay her creditor. Thus bankruptcy laws appear as naturally required rules of the game.
- A basic money is part of the rules supplied by society and at least sanctioned by government. Gold provides a classical example of a commodity money. One of the major cures for the shortage of a commodity money has been to replace it by a government or fiat money.
- The introduction of a fiat money and taxation and subsidy to at least provide partial control over its distribution represented a basic jump in the power of the central government. The analysis of the support for the valuation of commodity money versus fiat money has been taken in terms of separating transactions and consumption values for each and considering that a commodity money can only be used for one of its functions during any minimal period of time.
- The need for flexibility in the money supply and the importance of evaluation of the magnitudes involved provides sufficient incentives for the utilization of both the national debt and commercial banks.

- The creation of financial institutions as sufficient vehicles to provide the necessary services of risk amelioration in a more and more mass high information, computation and communication economy run primarily by fiduciaries is called forth to ameliorate the losses from incomplete markets. Insurance companies of many varieties, derivative instruments, secure and unsecured lenders all provide instruments that aim towards the ideal of completing the markets that exists in its Platonic form in general equilibrium theory
- Figure 3 above shows the elementary structure of a minimal process model that is sufficient to pick up the primary functions of a process economy. With a more explicit treatment of risk it describes the new paradigm to go beyond general equilibrium theory where government, money and financial institutions are required to link the economy to the polity and society.

6 References

References

- [1] Allais, M. 1947. *Économie et intérêt*. Paris: Imprimerie Nationale.
- [2] Angerer, M., Huber, J., M. Shubik, S. Sunder. 2010. “An Economy with Personal Currency: Theory and experimental evidence” in *Annals of Finance*, 6(4), 475-509.
- [3] Amir, R., S. Sahi, M. Shubik and S. Yao, 1990. A strategic market game with complete markets. *JET* 51, 1: 126-143.
- [4] Bellman, R. E. 1957. *Dynamic programming*. Princeton: Princeton University Press.
- [5] Bertrand, J. 1883 Book review of *theorie mathematique de la richesse sociale* and of *recherches sur les principes mathematiques de la theorie des richesses*, *Journal de Savants* 67: 499–508
- [6] Black, F. 1970 . Banking and interest rates in a world without money: The effects of uncontrolled banking. *Journal of Banking Research* 1:8–20.
- [7] Burke, J. 2012. Eliminating Sunspot Effects in Overlapping Generations Models. *Economics Letters*, Vol. 117, 828-830.
- [8] Augustin A. Cournot, A.A. *Researches into the Mathematical Principles of the Theory of Wealth* New York: The Macmillan Co., 1897.
- [9] Debreu, G.. 1959. *Theory of Value*. Yale Wiley, New York.

- [10] Dubey, P. K. 1982. Price-Quantity Strategic Market Games. *Econometrica*, 50(1), 111-126. doi:10.2307/1912532
- [11] Dubey, P. K., S, Sahi and M. Shubik. Minimally complex exchange mechanisms: Emergence of prices, markets and money CFDP 1945
- [12] Dubey. P. K. and M. Shubik 1978 Noncooperative Equilibria of a Closed Trading Economy with Market Supply and Bidding Strategies, *Journal of Economic Theory*, 17, 1: 1-20.
- [13] Dubey, P. K. and L. S. Shapley. Noncooperative exchange with a continuum of traders.
- [14] Edgeworth, F. Y. 1925 *Papers Relating to Political Economy*, Vol. I London: Macmillan and Co., pp. 111-142;
- [15] Geanakoplos, J.G. and H. Polemarchakis 1984 “Intertemporally Separable Overlapping Generations Economies” *Journal of Economic Theory* 34(2): 207-215.
- [16] Goetzmann, W. N and K. G. Rouwenhorst, , eds. 2005. *The Origins of Value: The Financial Innovations That Created Modern Capital Markets*. Oxford and New York: Oxford University Press, pp. xii, 404.
- [17] Hayek F. A. 1935 *Collectivist Economic Planning: Critical Studies on the Possibilities of Socialism*. Routledge, New York.
- [18] Hotelling, H. 1929. Stability in competition. *Economic Journal* 39:57.
- [19] Huber, J., M. Shubik and S. Sunder 2014. Sufficiency of an Outside Bank and a Default Penalty to Support the Value of Fiat Money: Experimental Evidence, *Journal of Economic Dynamics and Control*, 47: 317-337.
- [20] Jevons, W. S. 1875. *Money and the mechanism of exchange*. London: Macmillan.
- [21] Karatzas, .I, M. Shubik and W. Sudderth. 1994, “Construction of Stationary Markov Equilibria on a Strategic Market Game. *Mathematics of Operations Research*, 19, 4: 975-1006.
- [22] Lucas R. 1972. Expectations and the Neutrality of Money. *Journal of Economic Theory*, 4:103-124.
- [23] Samuelson, P. A. 1958. An exact consumption loan model of interest with or without the social contrivance of money. *Journal of Political Economy* 66 (6):467–480.

- [24] Sahi, S., and S. Yao. 1989. The noncooperative equilibria of a trading economy with complete markets and consistent prices. *Journal of Mathematical Economics* 18 (4):325–346.
- [25] Schumpeter, J. A. 1934. *The theory of economic development*. Cambridge: Harvard University Press.
- [26] Shapley, L. S. 1976. Noncooperative general exchange. In S. A. Y. Lin, ed., *Theory and measurement of economic externalities*. New York: Academic Press, 155–175.
- [27] Shapley L. S. and M. Shubik, 1977, Trade Using One Commodity as a Means of Payment, *The Journal of Political Economy*, 85, 5, 937-968.
- [28] Shubik, M. and D. E. Smith 2016. *The Guidance of an Enterprise Economy*. Cambridge Mass. MIT Press.
- [29] Shubik, M. 1973, Commodity Money, Oligopoly, Credit and Bankruptcy in a General Equilibrium Model, *Western Economic Journal*, 11, 1, 24-38
- [30] Shubik, M. 1999. *The Theory of Money and Financial Institutions Volume 1*, Cambridge, MA; UK: MIT Press.
- [31] Shubik, M. 2011. *The Theory of Money and Financial Institutions Volume 3*, Cambridge, MA; UK: MIT Press.
- [32] Shubik, M. and C Wilson. 1977. The Optimal Bankruptcy Rule in a Trading Economy Using Fiat Money. *Zeitschrift fur Nationalokonomie*, 37, 3-4: 337-354.
- [33] Sorin S. 1996. Strategic Market Games with Exchange Rates. *Journal of Economic Theory* 68: 431-446
- [34] Stokey, L. S. and R. E. Lucas 1989 *Recursive Methods in Economic Dynamics*. Harvard University Press. Cambridge MA.
- [35] Von Neumann, J. 1945. A model of General Economic Equilibrium, *Review of Economic Studies* 13:1-9 (translated from German, 1938)